



Solenoid and Motor Driven Dosing Pump

- IP 55 protection against water jets and dust
- High-grade components for chemical compatibility, durability and extended service life
- Standard PVDF pump head
- Standard ceramic ball valve
- Solenoid type diaphragm is made of pure solid PTFE



HMS-200 HML-200 Solenoid Dosing Pump



HMS-200 and HML-200 are single frequency, micro processor controlled solenoid dosing pumps with constant flow rate and easy operation.

Specification		
Pressure Bar (pipe)	8	10
Flow Rate (L/H)	5	3
Stroke (ml/min)	0.52	0.31
Frequency	160	
Connector	1/2"-3/8" Thread, PVC	



Operation instruction	
	Manually adjustable flow rate control dial on the front panel with power-on LED indicator HML series with level control input.
Flow Rate Adjust Range	0-100%

Information		
Outer Shell	PP	IP65
Valve Head	Pump head: PFDV	I/O valve: PVDF
	Ball valve: ceramic	Diaphragm: PTFE
Power Supply	240V / 50Hz for HMS series :12W 100-240V / 50-60Hz for HML series :12W	
Installation	Wall-mounted / Vertical	
Net Weight	2.4Kg	

Measurements

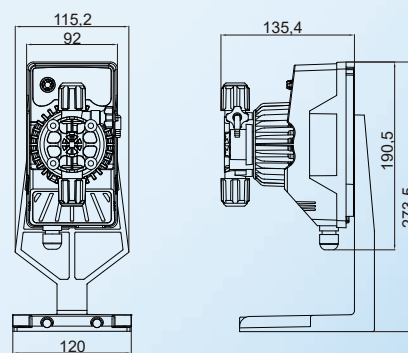

Installation Kit



Injection valve



foot valve



delivery tube



PVC suction tube



Wall-mounted bracket x 1



Vertical-mounted bracket x 1

HKL-600 HKL-800 Solenoid Dosing Pump



HKL-600 and HKL-800 are stable and easy operation electronic controlled dosing pumps with two frequency adjustable and level control input.

Specification								
Model	HKL-600				HKL-800			
Pressure Bar (pipe)	20	19	14	8	12	10	5	1
Flow Rate (L/H)	2.5	3.0	4.2	7	7	10	15	18
Stroke (ml/min)	0.35	0.42	0.58	0.97	0.36	0.52	0.78	0.94
Frequency	120				300			
Connector	1/2"-3/8" Thread, PVC							

Operation instruction		
	Two frequency manually adjustable flow rate control dial on the front panel with power-on LED indicator and level control input.	
Flow Rate Adjust Range	:5--0-20%	:1--0-100%

Information		
Outer Shell	PP	IP65
Valve Head	Pump head: PFDV	I/O valve: PVDF
	Ball valve: ceramic	Diaphragm: PTFE
Power Supply	100-240V / 50-60Hz for HKL-600 :20W 100-240V / 50-60Hz for HKL-800 :40W	
Installation	Wall-mounted / Vertical	
Net Weight	HKL-600 : 3.9Kg HKL-800 : 4.4Kg	

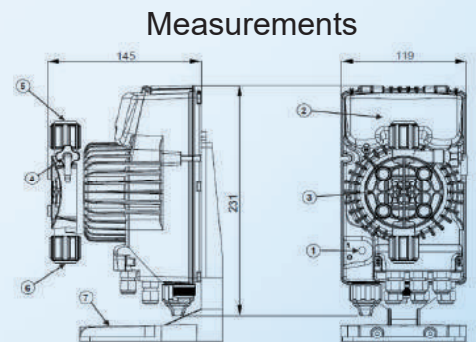
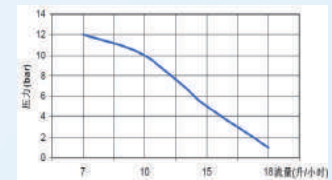

Installation Kit



Injection valve



foot valve



delivery tube



PVC suction tube



Wall-mounted bracket x 1



Vertical-mounted bracket x 1

MDP Series Motor Driven Dosing Pump



Flotrol MDP motor driven dosing pump is a type of pump designed to provide accurate and reliable measurements in a variety of industrial applications. This pump uses the principle of mechanical diaphragm movement to produce a flow of chemicals or liquids at the desired pressure. Liquid flow can be easily adjusted by flow adjusting knob and it is convenient for installation and maintenance.

Specification			
Model	MDP-10-053CB	MDP-07-115CB	MDP-07-242CB
Flow Rate (L/H)	53	115	242
Max. Pressure (bar)	10	7	7
Stroke Rate (stroke/min)	78	156	116
Stroke Length (mm)	4	4	6.4
Diaphragm Diameter (mm)	96	96	124
Power Supply	380V / 3Ph / 50Hz		
	0.25KW	0.37KW	0.37KW
Material of Pump Head	PVDF		
Material of O-ring	EPDM		
Connections	G3/8	G3/8	G3/4
Max. Temperature	40°C		
Gross Weight (kg)	16	16	20
Carton Size (mm)	L450 x W300 x H550		

1. With exception to standard motor, it is also can be equipped with frequency-conversion motor.
2. Test with water @ 20°C @ 50 Hz; Flow rate values with motor at 50Hz. Multiply by 1.2 for 60 Hz

Measurements			
Model	MDP-10-053CB	MDP-07-115CB	MDP-07-242CB
A (mm)	222	222	293
B (mm)	108	108	118
C (mm)	301	301	322

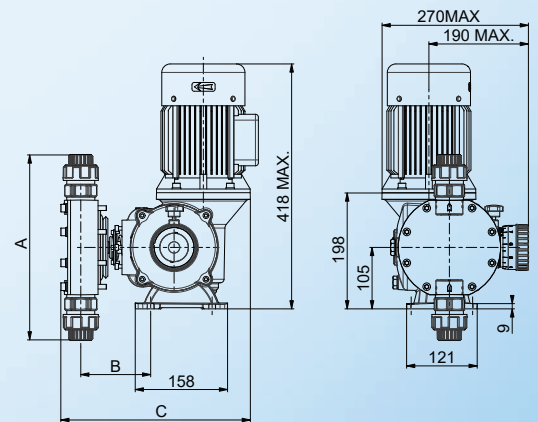

Please contact for more information.